

Adaptive Neuro-Fuzzy Model with Fuzzy Clustering for Nonlinear Prediction and Control

M.N.Obrovac, Dalhousie University, Canada

ABSTRACT--- *Nonlinear systems have more complex manner and profoundness than linear systems. Thus, their analyses are much more difficult. This paper presents the use of neuro-fuzzy networks as means of implementing algorithms suitable for nonlinear black-box prediction and control. In engineering applications, two attractive tools have emerged recently. These two attractive tools are: the artificial neural networks and the fuzzy logic system. One area of particular importance is the design of networks capable of modeling and predicting the behavior of systems that involve complex, multi-variable processes. To illustrate the applicability of the neuro-fuzzy networks, a case study involving air-fuel ratio is presented here. Air-fuel ratio represents complex, nonlinear and stochastic behavior. To monitor the engine conditions, an adaptive neuro-fuzzy inference system (ANFIS) is used to capture the nonlinear connections between the air-fuel ratio and control parameters such manifold air pressure, throttle position, manifold air temperature, engine temperature, engine speed, and injection opening time. This paper describes a fuzzy clustering method to initialize the ANFIS.*

Keywords- ANFIS, Fuzzy Clustering, Air-fuel ratio

1. INTRODUCTION

Researches have been conducted in the engineering field during decades in order to apply the artificial intelligent algorithms. The application refers to the advantages which the non-linear of arbitrary complexity and their performances are being dealt. The learning capability [10] of a neural network and the advantages that the rule-based fuzzy system contains lead the neuro-fuzzy systems to improve the level of performance observed and also incorporates past observations during the prediction process.

Fuzzy logic systems (FLS) and artificial neural networks (ANN) are mathematical disciplines that are very applied to a wide range of engineering applications [1]. The FLS [12] and ANN are capable of: (1) finding complex, nonlinear and hidden relationships found in the presented data; (ii) predicting the behavior of the system; (iii) functional generalization and as such acceptably responding to the situations to which they have not been exposed before; and (iv) offering alternative solutions when the system cannot be expressed in terms of equations. FLSs [4] are capable to formulate nonlinear input-output relationships by a set of if-then rules, which enables both the numerical data and linguistic knowledge to quantify the means of traditional mathematics. The main advantage of ANNs, is located in the learning capability, which adapts the networks to improve their performance.

In a neuro-fuzzy scheme, fuzzy logic definitions are used to build the system and then refined using neural network training algorithms. ANFIS, FCM were used to build the proposed system. So, brief information about them will be given first.

2. ANFIS

ANFIS is a simple data learning method uses a fuzzy inference system model by developing membership functions for each input to convert a crisp input into a target output. The basic concept behind these neuro-adaptive learning techniques is let the fuzzy modeling procedure get benefit of neural networks to learn information about a data set, in order to allow the associated FIS to work out the given input/output data by reaching the best membership function parameters.

A hybrid learning algorithm was implemented by Jang [6] which converges faster than using gradient method alone. During the forward pass, the node outputs progress until the output membership function layer, where the least-squares method identifies the consequent parameter. While the backward pass uses a backpropagation gradient descent method, which offers a measure of how well the FIS is modeling the input/output data for a given set of parameters. Based on the error signals that propagate in the backward pass, the premise parameters are updated. The consequent parameters determined are optimal under the condition that the premise parameters are fixed. It helps reducing the dimension of search space for the gradient descent algorithm which secures the fast convergence.

This approach [2][8] has the advantage over the pure fuzzy paradigm where the need of human operator, to adjust the bounds of the membership functions in order to tune the system, is removed. In this paper, ANFIS is chosen as a control strategy due to its simple structure and takes advantage of both fuzzy logic and adaptive neural networks. The adaptive neural networks have the advantages of being able to learn, and adapt to the system.

The fuzzy ‘if-then’ rules and membership functions can be refined by the ANFIS, to describe the input/output behavior of a complex nonlinear system. In practical applications, Sugeno type [3] FISs have been considered more suitable for constructing fuzzy models due to their more compact and computationally-efficient representation of data than the Mamdani fuzzy systems. A zero-order Sugeno fuzzy system has been used here and has the form:

$$\text{If } x \text{ is } A \text{ and } y \text{ is } B \text{ then } z = c$$

where A and B are fuzzy sets and z is a crisply defined function. A singleton spike is often completely sufficient to satisfy the needs of a given problem.

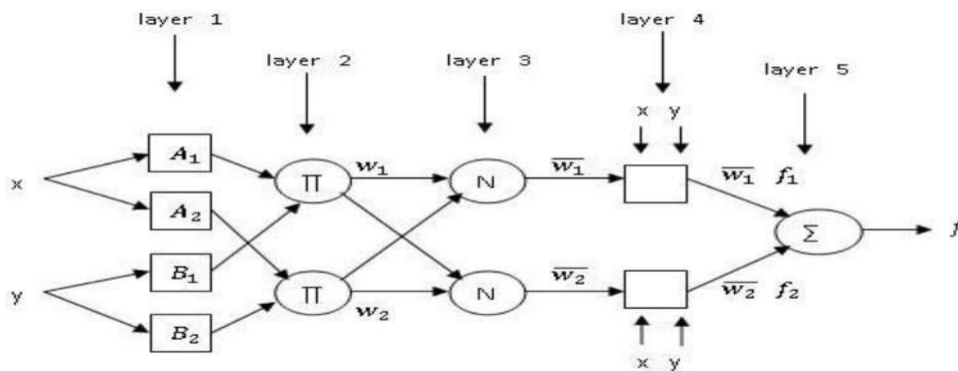

Figure 1: ANFIS Sugeno fuzzy system

ANFIS has five layers as shown in Figure 1. The first hidden layer is responsible of the mapping of the input variable relatively to each membership functions. In the second layer, the operator T-norm is applied to calculate the antecedents of the rules. The rules strengths are normalized in third hidden layer followed by the fourth hidden layer that determines the consequents of the rules. The output layer calculates the global output as the summation of all the signals that arrive to this layer.

3. DATA CLUSTERING

Data clustering functions as an intelligent tool, a method that allows the user to handle large volumes of data effectively. To achieve the accurate representation of the original data, data of any origin is transformed into a more compact form, which represents the basic function of data clustering that results in a concise representation of a system’s behavior. The compact representation should allow the user to deal with and use the original volume of data more effectively. The accuracy of the clustering is essentially because if the compact form of the data does not accurately represent the original data, it will produce in an unsuccessfully process.

Traditional clustering analysis is a hard partition, where each object is identified to a certain category, but in the world many of the practical issues does not have a strict behavior which are an intermediary, so it is suitable for soft partition. Fuzzy set theory proposed by Zadeh [9] provides a powerful analytical tool for this soft partition.

3.1 Fuzzy C-Means

Fuzzy c-means (FCM) is a data clustering technique [11] wherein each data point belongs to a cluster to some degree that is specified by a membership grade. This technique was originally introduced by Jim Bezdek in 1981 [5] as an improvement on previous clustering methods. The new technique provided a method which elaborate on how data points

are being grouped. The group helps to populate certain multidimensional space into special number of different clusters. Less processing time and fewer rules were achieved by FCM method. The FCM clustering is an iterative algorithm using the necessary conditions for a minimizer ($\mu; A$) of the objective function J_{FCM} .

$$J_{FCM}(\mu, A) = \sum_{i=1}^c \sum_{j=1}^n \mu_{ij}^m \|X_i - A_j\|^2, \quad m > 1, \quad (1)$$

where m is any real number greater than 1, μ_{ij} is the degree of membership of x_i in the cluster j , x_i is the i -th of d -dimensional measured data, A_j is the d -dimension center of the cluster, and $\|*\|$ is any norm expressing the similarity between any measured data and the center.

$$A_i = \frac{\sum_{j=1}^n \mu_{ij}^m X_j}{\sum_{j=1}^n \mu_{ij}^m}, \quad i = 1, \dots, c \quad (2)$$

and

$$\mu_{ij} = \mu_i(X_j) = \left(\sum_{k=1}^c \frac{\|X_j - A_i\|^{2/(m-1)}}{\|X_j - A_k\|^{2/(m-1)}} \right)^{-1}, \quad i = 1, \dots, c, \quad j = 1, \dots, n. \quad (3)$$

4 AIR-FUEL RATIO

High output performance, stringent fuel consumption and emission regulations are considered as one of the major challenged faced by engineers. The high demands make the engineering filed complicated, especially those for control engineers. The key for better engine performance and reduced exhaust emissions are being held in the level of precise control of air-fuel ratio (AFR), during both steady and transient engine operation [7].

Fuel has to be precisely mixed in a stoichiometric 14.7:1 ratio, to get a clean exhaust. The mixture also has to be ignited at a precise moment that varies with several factors, such as load, speed and others. AFR control would not be difficult to handle with if engines always operate at steady state, but going across a practical driving cycle, the engine will across many transients including rapidly changing speed and load requirements. During, engine transients, when the throttle position is changed, the fact that processes which regulate the air and the fuel flow to the cylinder are substantially different leading to momentary undesirable AFR excursions.

The AFR control is a difficult task due to its non- linearity. Classical control techniques such as proportional-integral-derivative (PID), proportional-integral (PI), and various adaptive controllers have been used for a long time to control the air fuel ratio. The problem with these techniques is that they are designed based on the mathematical model of the system and do not work well in nonlinear circumstances. Due to the drawbacks of PID, PI and various adaptive controllers to overcome the short coming of these controllers, industrial control applications use intelligent controllers such as neural network controller, fuzzy inference controller, and neuro-fuzzy controller.

5 PROPOSED MODEL

The paper includes the prediction and control of engine air-fuel ratio. Modeling is done by fuzzy clustering and ANFIS. Firstly, inputs and outputs factors of a gasoline engine are replaced as part of system. Later, these factors are grouped into optimal numbers independently by using fuzzy clustering algorithm as a preprocessing step. Later on, these optimal numbers of clustered parameters are used as inputs and outputs of ANFIS for the prediction and control process. Inputs of the system are Manifold Air Pressure (MAP), Throttle Position (TPS), Manifold Air Temperature (MAT), Engine Temperature (CLT), Engine Speed (RPM), and Injection Opening Time (PW) whereas output is AFR, as shown in Figure 2.

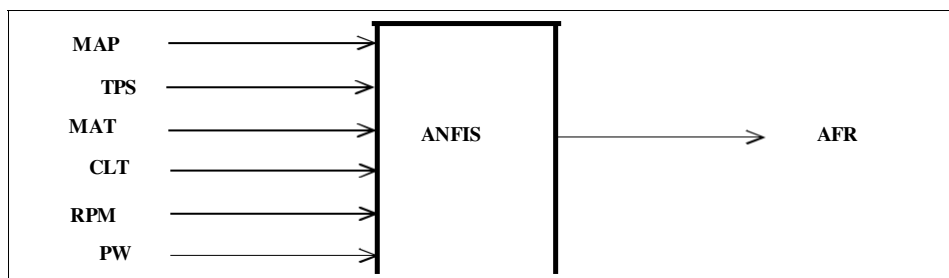

Figure 2: Block diagram of proposed ANFIS model

In this section we build our nonlinear prediction and control model through a multistep procedure:

Step1: Data Collection

A large collection of engine data was generated using test engine. In this step a number of factors which seem to have most influences on air-fuel ratio have been chosen. Six factors have been determined as the most influential factors, which are, Manifold Air Pressure (MAP), Throttle Position (TPS), Manifold Air Temperature (MAT), Engine Temperature (CLT), Engine Speed (RPM), and Injection Opening Time (PW). An ANFIS have been used to train each combination of factors for one epoch to show the most influence factors with the lowest training and testing errors. From Figure 3, it is illustrated that different combinations that includes all of the factors resulted in close results that have the lowest training and testing errors. The training and checking errors are comparable, which implies that there is no over fitting.

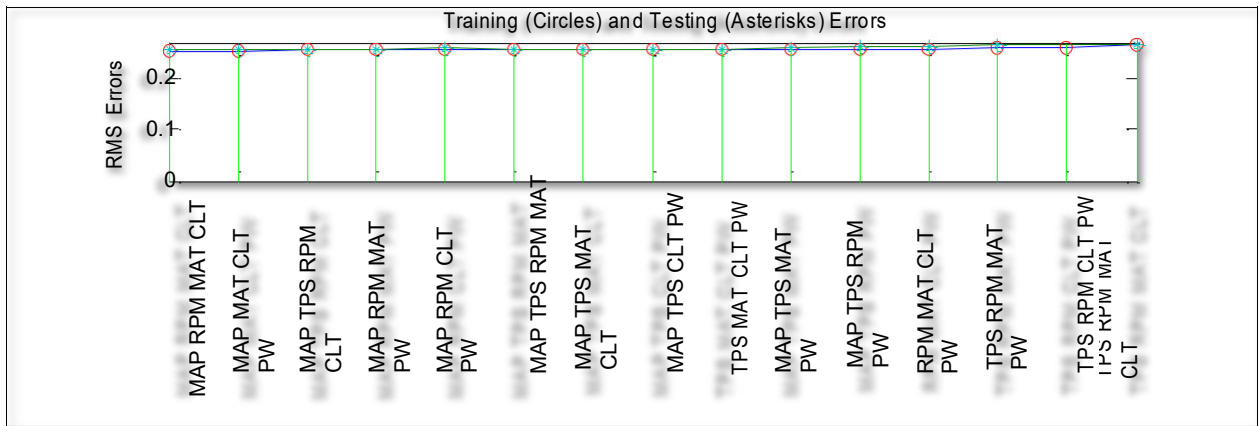

Figure 3: Most Influence Factors

The data sets include engine operation for steady and transient states. Using a dataset containing 20,600 instances divided between the training and testing data that have chosen randomly from the dataset. The factors data ranges as: MAP [0 - 1.05] bar, TPS [0% - 194.49%], RPM [0 - 8900] revelation per minute, MAT [26.7C° - 34.4 C°], CLT [29 C° - 141 C°], and PW [0.6ms – 7.9ms].

Step2: Fuzzy Clustering

In order to implement the ANFIS, the membership initial values need to be reached. The FCM algorithm was applied as a preprocessing for the ANFIS model, in order to reach the clusters centers and the membership degree for the inputs. Fuzzy c-means clustering is carried out through an iterative optimization of the objective function. The number of clusters was eight clusters for each input [MAP, TPS, RPM, MAT, CLT, PW], the number of clusters determines the number of rules and membership functions in the generated fuzzy inference system (FIS). The minimization of the objective function depending on equation (1), reached the value zero. Gaussian membership functions were implemented in this work due their smoothness and non-zero at all points .Figure 4 shows the initial membership sets achieved from the FCM algorithm.

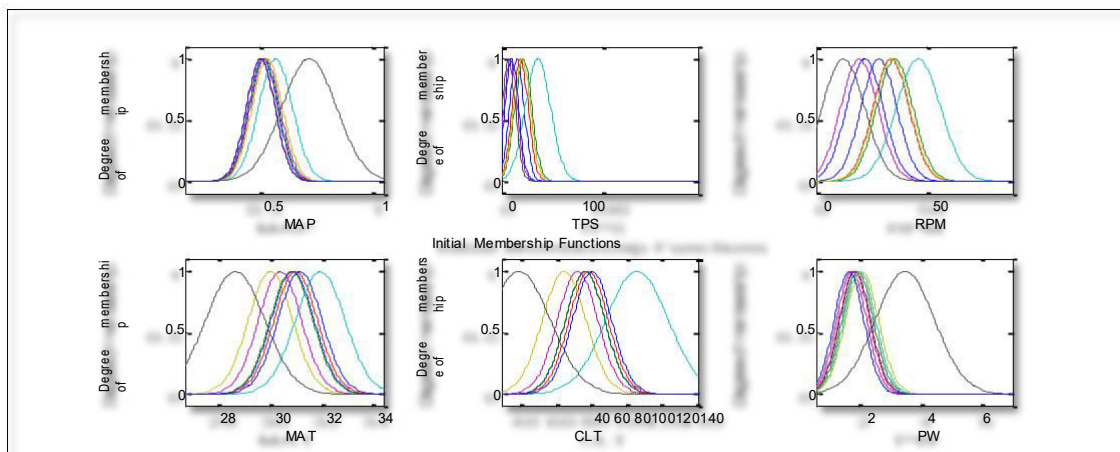

Figure 4: Initial Membership Sets

Step3: ANFIS Model Training and Evaluation

The training data set was used by the ANFIS to train the Sugeno-type FIS by applying a hybrid learning algorithm to identify membership function parameters. It applies a combination of the least-squares method and the back-propagation gradient descent method to simulate a given training data set. The ANFIS also refines the fuzzy ‘if-then’ rules to describe the input/output relation of a nonlinear complex system. Eight ‘if-then’ rules were used, determined from the clustering algorithm depending on the number of clusters. Figure 5 shows the final membership functions for each input generated by the ANFIS.

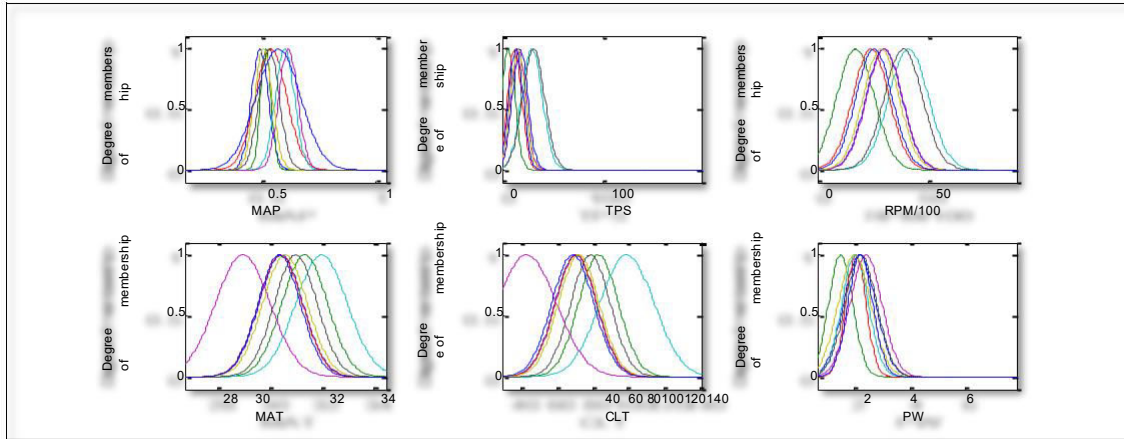

Figure 5: Final Membership Sets

The root mean square error (RMSE) was used to evaluate the predicted air-fuel ratio using ANFIS model compared to actual air-fuel ratio obtained from experiments.

$$RMSE = \left(\frac{\sum_{i=1}^n (y' - y)^2}{(n - 1)} \right)^{\frac{1}{2}} \quad (4)$$

where y' is the predicted output, y is the actual output and n is the number of data.

Figure 6 shows that that training error and testing error were declining as the number of epochs increased. Based on the obtained results from Figure 6, the ANFIS proved its capability to predict the air-fuel ratio by decreasing the rate of training and testing errors while increasing the level of accuracy.

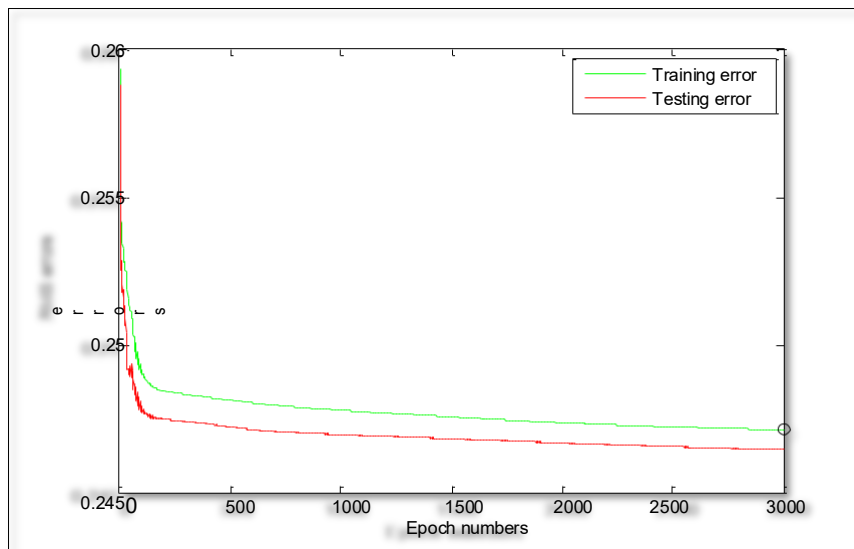

Figure 6: ANFIS performance

6. CONCLUSION

The objective of this study was to result in an ANFIS to maintain appropriate performance of the engine air-fuel ratio predict and control in the presence of uncertainty and variations in system parameters. The ANFIS model got use of the initialization of membership functions by the FCM algorithm to improve its performance. It was shown that ANFIS model works satisfactorily for nonlinear models such as the one presented in the case study. The performance of the model was evaluated based on the performance of training and accuracy of prediction.

REFERENCES

- [1] A. R. Sadeghian, "Nonlinear Neuro-Fuzzy Prediction: Methodology, Design and Applications", 2001.
- [2] C.J. Harris, M. Brown, K.M. Bossley, D.J. Mills, F. Ming, "Advances in Neurofuzzy Algorithms for Real-time Modelling and Control", Engineering Applications of Artificial Intelligence, Vol. 9, Issue 1, pp. 1-16, February 1996.
- [3] E. Gorrostiet, J.C. Pedraza, R.J. Carlos, "Fuzzy Modelling of Systems", Proceedings of 11 th IEEE International Conference on Methods and Models in Automation and Robotics MMAR 2005, 29 August- 1 September 2005, Miedzydroje, Poland. ISBN 83-60140-85-5.
- [4] H. O. Wang, K. Tanaka, and M. F. Griffin, "An approach to fuzzy control of nonlinear systems: stability and design issues", IEEE Trans. on Fuzzy Systems, vol. 4, no. 1, pp. 14-23, February 1996.
- [5] J.C. Bezdek, Pattern Recognition With Fuzzy Objective Function Algorithms, Plenum Press, New York, 1981.
- [6] J. Jang, "ANFIS: Adaptive network-based fuzzy inference systems", IEEE Transactions on Systems, Man, and Cybernetics 23, pp.665-685, 1993.
- [7] J. Lauber, T. M. Guerra, M. Dambrine, "Air-fuel ratio control in a gasoline engine". International Journal of Systems Science, Vol. 42, No. 2, pp. 277-286, 2011.
- [8] K.P. Mohanadas and S. Karimulla, "Fuzzy and neuro-fuzzy modelling and control of nonlinear systems".
- [9] L.A. Zadeh, "Fuzzy sets", Information Control 8 pp.338-353, 1965.
- [10] L. Hong-Xing, C. L. Phillip Chen, "The equivalence Between Fuzzy Logic and Feedforward Neural Networks", IEEE Trans. On Neural Networks, vol. 11, no. 2, March 2000.
- [11] M.S. Yang, C.H. Ko, "On a class of fuzzy c-numbers clustering procedures for fuzzy data", Fuzzy Sets and Systems 84, 49-60, 1996.
- [12] Robert fuller, Introduction to Neuro-Fuzzy Systems, springer, 2000.